

GUARDIAN® Series 2

18.0kg/39.7lb Gravimetric Batch Blender

Standard Features

Each hopper has one 90° side and no transition sections for improved material flow.

Hopper access doors with secure latching system.

Cartridge style dispensing gates w/ only 4 bolts to remove, for ease of maintenance and clean out.

Optimized V-design metering gates for improved accuracy and dispensing range.

6" color touch screen operator interface with "off-the-shelf" industrial controller.

Remote communications: Built-in Ethernet port standard - various protocols supported.



**See-Through
Mixing Chamber
Door - Allows
for Visual
Monitoring of
Blend Quality**

**Rated at up to 5,100 lbs/hr throughput
with a 18.0 kg/39.7 lb batch size**

The Guardian® Series 2 gravimetric batch blender was developed for manufacturers and businesses who want simplicity of operation combined with the most accurate dispensing and superior blend homogeneity, all at a low cost. For these customers, Process Control designed the Guardian® Series 2.

The 18.0 kg weigh scale type blender in the Guardian® Series 2 family has been made with redesigned material hoppers to hold each of the ingredients. The 18.0 kg blenders can be supplied with up to six separate ingredient hoppers as standard.

The outlet of each of the individual material hoppers is equipped with a fast acting V-gate valve. Each of the materials is dispensed sequentially into a common weighing hopper in the desired proportions. The weighed materials are then released into a separate "No Dead Zone" mixing chamber, which provides the most consistent homogeneous blend of any batch type blender.

Process Control engineers have developed a highly

advanced dispensing and weighing system that accurately controls each ingredient of every batch to the desired amounts. This is uncommon in the industry, as other batch blenders use a dispensing system that averages results over multiple batches. At the blender's highest setting, each ingredient can be dispensed to an accuracy of +/- 0.02%!

In addition to precise batch-to-batch dispensing, the performance of the mixer is just as critical to the end product. The mixer actually determines how uniform the blend will be. In head to head comparisons with other manufacturer's gravimetric batch equipment, PCC mixing has been shown to be superior to the competition.

The Guardian® Series 2 blenders have incorporated a built in clean-out system in the design. With a pull-out drain chute and separate manual slide-gate controls, the blender can be cleaned out quickly and easily during product changeovers.

**Standard 6" touch screen
interface ensures ease of use
and quick startups**



PROCESS CONTROL CORPORATION

World Headquarters
6875 Mimms Drive, Atlanta, GA 30340 USA
Ph 770.449.8810 Fax 770.449.5445

Process Control GmbH
Industrie Str. 15, 63633 Birstein, Germany
Ph +49-6054-91290 Fax +49-6054-91299

4 Element, 18kg Guardian® Series 2 Blender

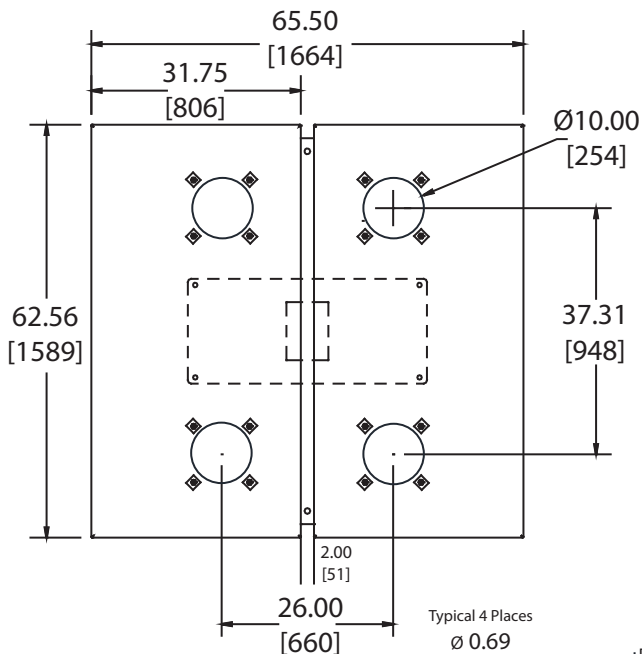

Top View

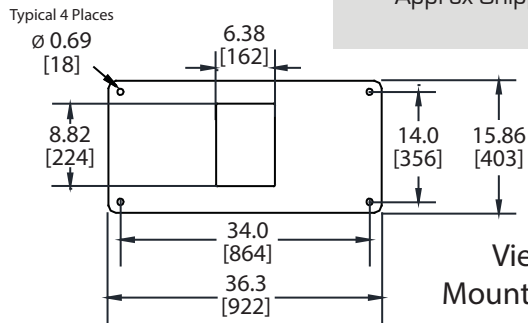

Maximum Throughput Rates

- 2-Element: 7000 PPH*
 - 3-Element: 5750 PPH*
 - 4-Element: 5100 PPH*
- *Depending on Materials, Mix Time & Accuracy Setting

Power

- 460V/3Ph/60Hz for mixer motor
- 115V/1Ph/60Hz for controls
- or
- 400V/3P/50Hz for mixer motor
- 230V/1Ph/50Hz for controls

[] Dimensions are in mm
Approx Shipping Weight: 750lbs

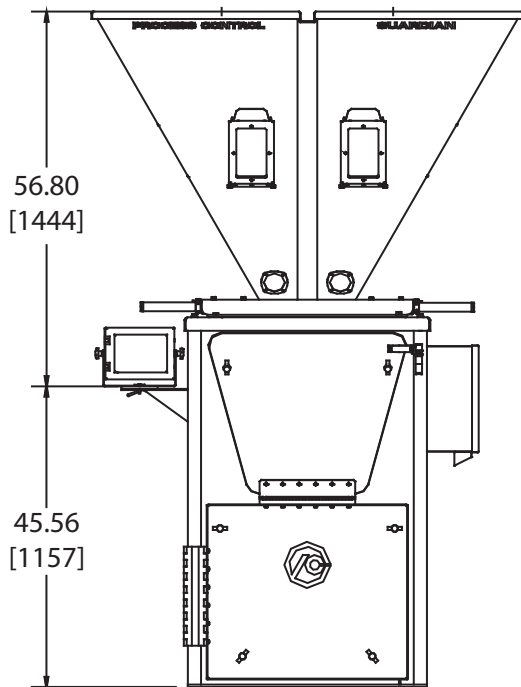

Front View

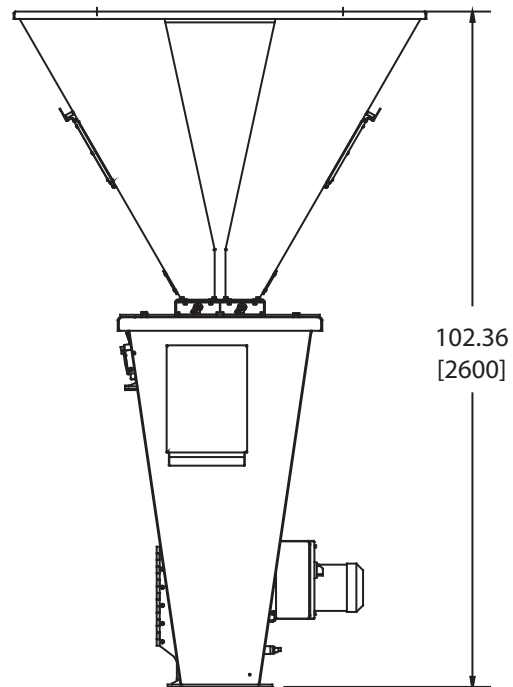

Side View

6 Element, 18kg Guardian® Series 2 Blender

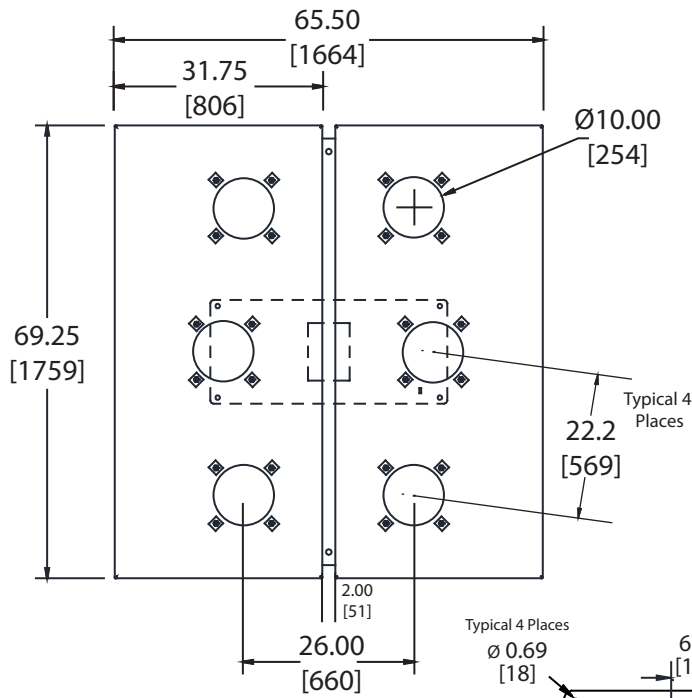

Top View

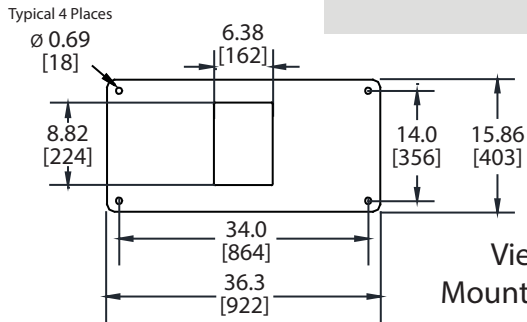

Maximum Throughput Rates

5-Element: 4300 PPH*
 6-Element: 3900 PPH*
 *Depending on Materials, Mix Time & Accuracy Setting

Power

460V/3Ph/60Hz for mixer motor
 115V/1Ph/60Hz for controls
 or
 400V/3P/50Hz for mixer motor
 230V/1Ph/50Hz for controls

[] Dimensions are in mm
 Approx Shipping Weight: 850lbs

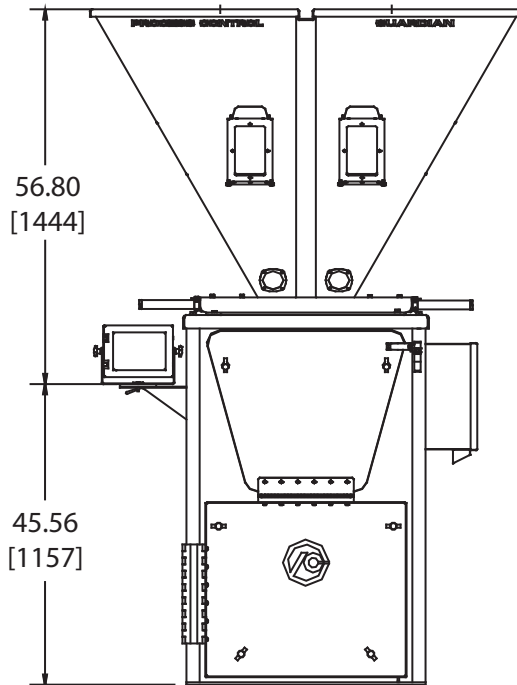

Front View

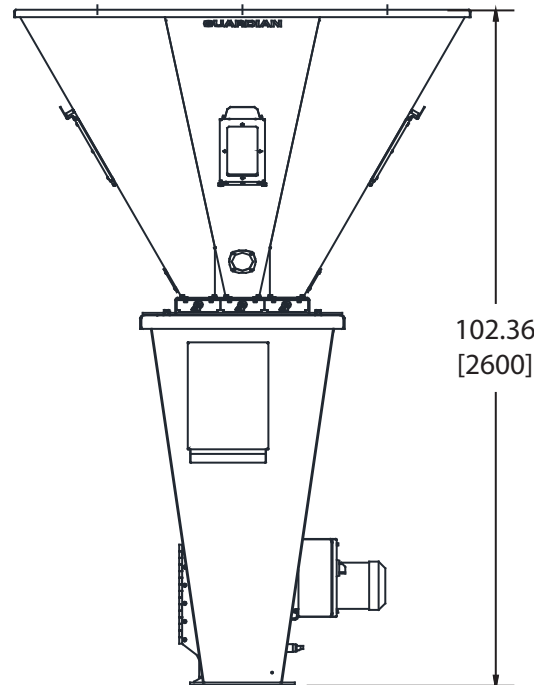

Side View

18kg Guardian® Series 2 Blender Optional Accesories

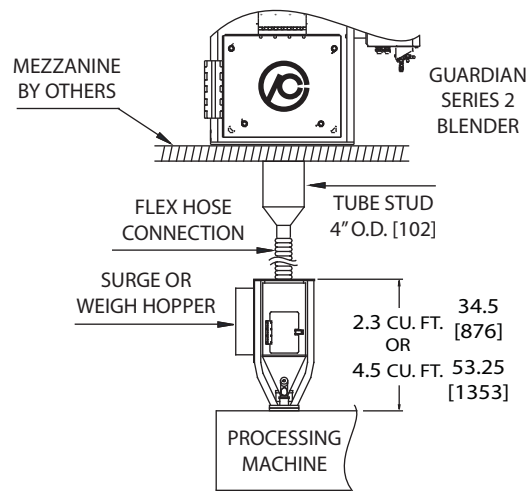
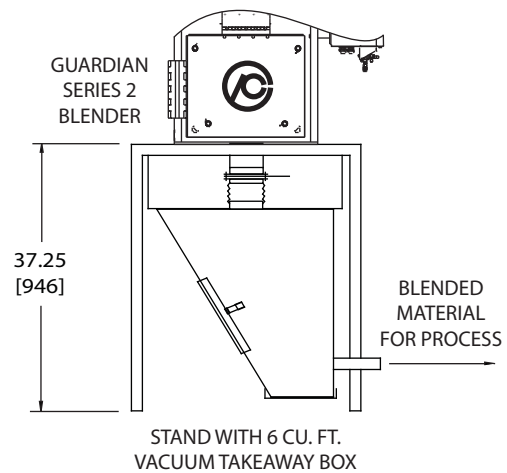
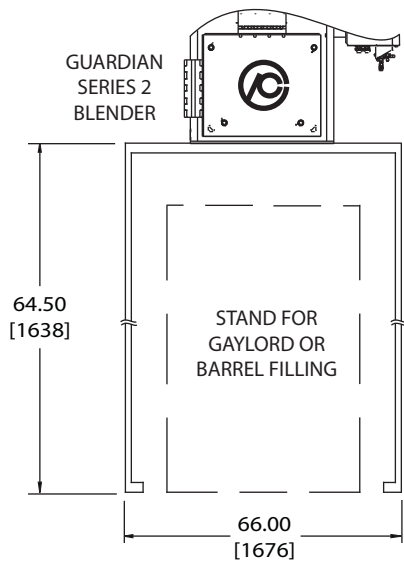

[] dimensions are in mm

Optional Features

- Dispensing gate restrictor plate for very low rate ingredients
- Integral extruder and linespeed control modules for mono-extrusion
- Extended cables for remote mounting touch-screen operator control panel
- Low level proximity sensor for material hoppers
- Drain with butterfly valve for material hoppers
- Regrind or Powder Feeder Elements
- Special Electricals
- Special Paint
- Blend Manager software
- Self-Loading Controls
- Up to 12 elements for 18kg
- For lower throughputs, see specification sheet for 2.5kg, 5kg, 12kg Guardian® Series 2 Gravimetric Blenders