

GUARDIAN® Series 2

2.5kg/5.5lb Gravimetric Batch Blender

Standard Features

Each hopper has one 90° side and no transition sections for improved material flow.

Hopper access doors with secure latching system.

Cartridge style dispensing gates w/ only 4 bolts to remove, for ease of maintenance and clean out.

Optimized V-design metering gates for improved accuracy and dispensing range.

6" color touch screen operator interface with "off-the-shelf" industrial controller.

Remote communications: Built-in Ethernet port standard - various protocols supported.



**See-Through
Mixing Chamber
Door - Allows
for Visual
Monitoring of
Blend Quality**

Rated at up to 820 lbs/hr throughput, with a 2.5 kg/5.5 lb batch size

The Guardian® Series 2 gravimetric batch blender was developed for manufacturers and businesses who want simplicity of operation combined with the most accurate dispensing and superior blend homogeneity, all at a low cost. For these customers, Process Control designed the Guardian® Series 2.

The 2.5 kg weigh scale type blender in the Guardian® Series 2 family has been made with redesigned material hoppers to hold each of the ingredients. The 2.5kg blenders can be supplied with up to six separate ingredient hoppers as standard.

The outlet of each of the individual material hoppers is equipped with a fast acting V-gate valve. Each of the materials is dispensed sequentially into a common weighing hopper in the desired proportions. The weighed materials are then released into a separate "No Dead Zone" mixing chamber, which provides the most consistent homogeneous blend of any batch type blender.

Process Control engineers have developed a highly

advanced dispensing and weighing system that accurately controls each ingredient of every batch to the desired amounts. This is uncommon in the industry, as other batch blenders use a dispensing system that averages results over multiple batches. At the blender's highest setting, each ingredient can be dispensed to an accuracy of +/- 0.02% !

In addition to precise batch-to-batch dispensing, the performance of the mixer is just as critical to the end product. The mixer actually determines how uniform the blend will be. In head to head comparisons with other manufacturer's gravimetric batch equipment, PCC mixing has been shown to be superior to the competition.

The Guardian® Series 2 blenders have incorporated a built in clean-out system in the design. With a pull-out drain chute and separate manual slide-gate controls, the blender can be cleaned out quickly and easily during product changeovers.

**Standard 6" touch screen
interface ensures ease of use
and quick startups**



PROCESS CONTROL CORPORATION

World Headquarters
6875 Mimms Drive, Atlanta, GA 30340 USA
Ph 770.449.8810 Fax 770.449.5445

Process Control GmbH
Industrie Str. 15, 63633 Birstein, Germany
Ph +49-6054-91290 Fax +49-6054-91299

4 Element, 2.5kg/5.5lb Guardian® Series 2 Gravimetric Batch Blender

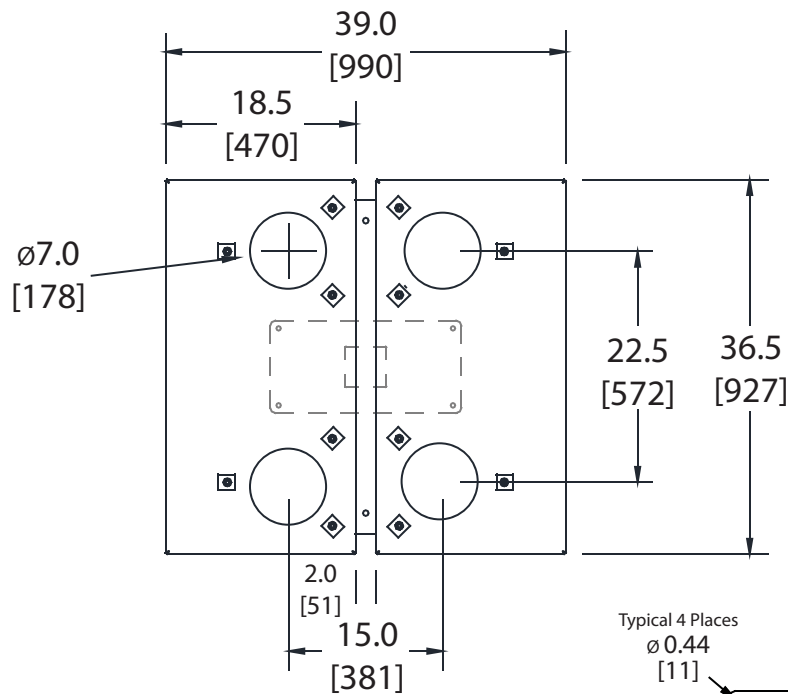

Top View

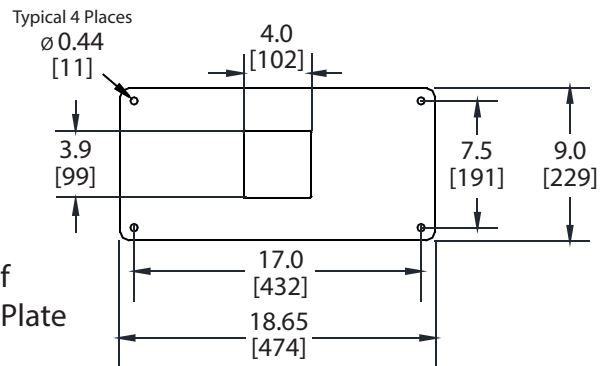

View of
Mounting Plate

Maximum Throughput Rates

2-Element: 820 PPH*

3-Element: 820 PPH*

4-Element: 820 PPH*

*Depending on Materials, Mix Time
& Accuracy Setting

Power

115V/1Ph/60Hz

or

230V/1Ph/50Hz

Bracketed [] dimensions are in mm
Approx Shipping Weight: 350lbs

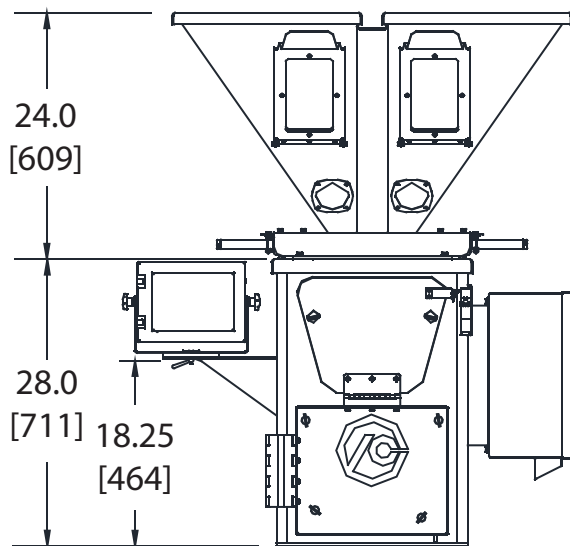

Front View

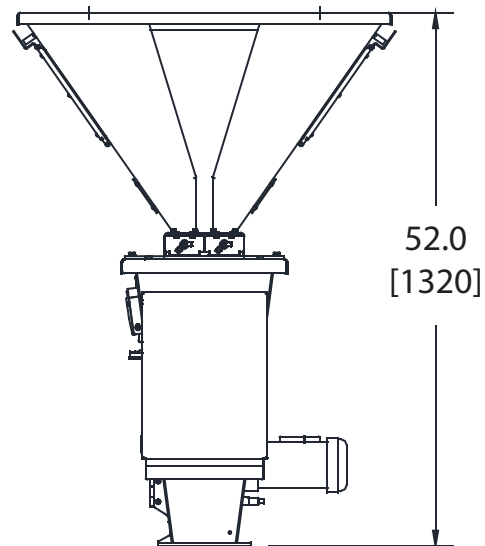

Side View

6 Element, 2.5kg/5.5lb Guardian® Series 2 Gravimetric Batch Blender

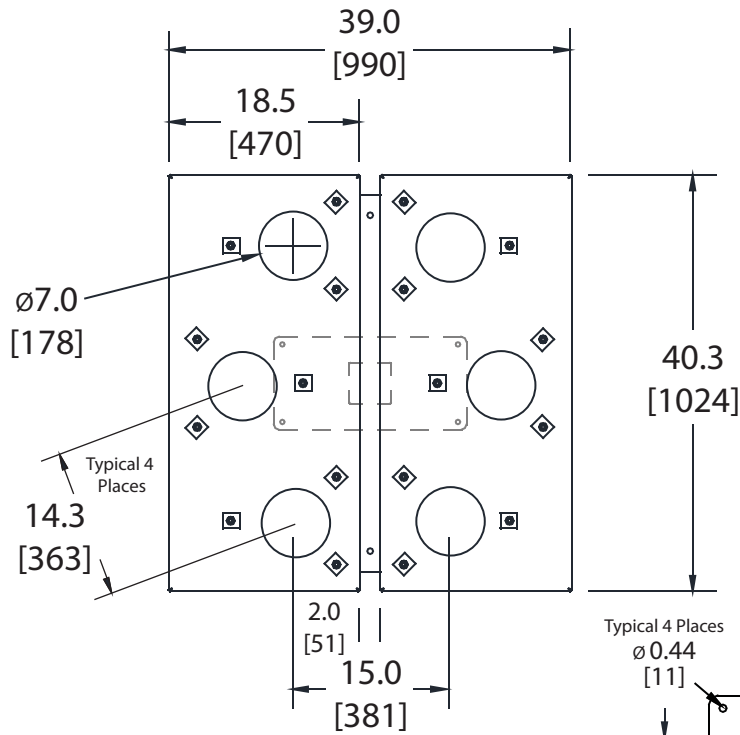

Top View

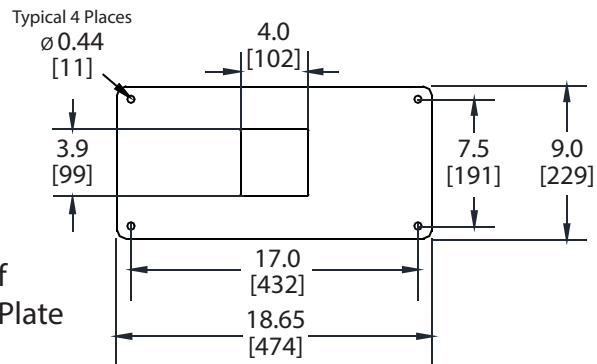

View of
Mounting Plate

Maximum Throughput Rates

5-Element: 700 PPH*

6-Element: 600 PPH*

* Depending on Materials, Mix Time
& Accuracy Setting

Power

115V/1Ph/60Hz

or

230V/1Ph/50Hz

Bracketed [] dimensions are in mm
Approx Shipping Weight: 425lbs

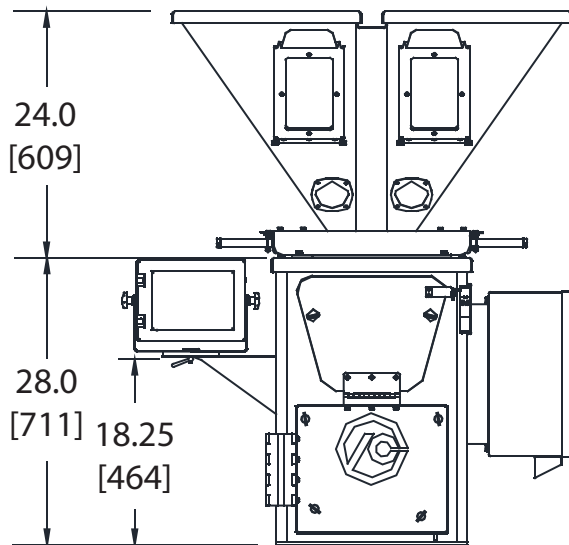

Front View

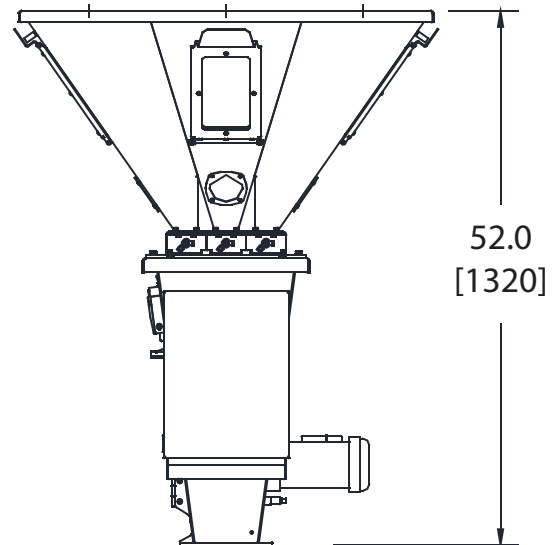

Side View

2.5kg/5.5lb Guardian® Series 2 Batch Blender Mounting Options and Accessories

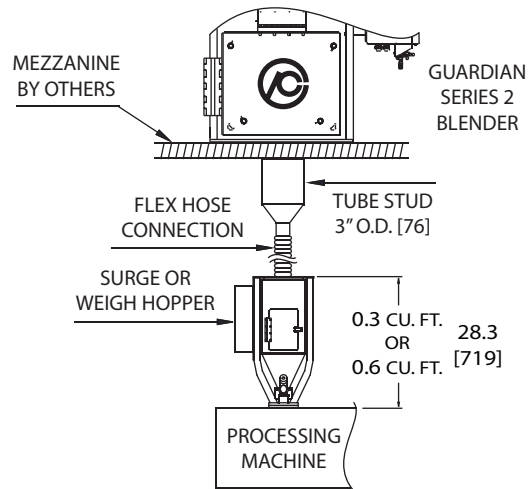
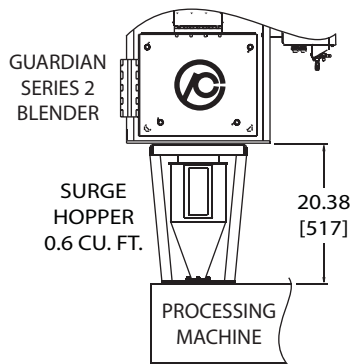
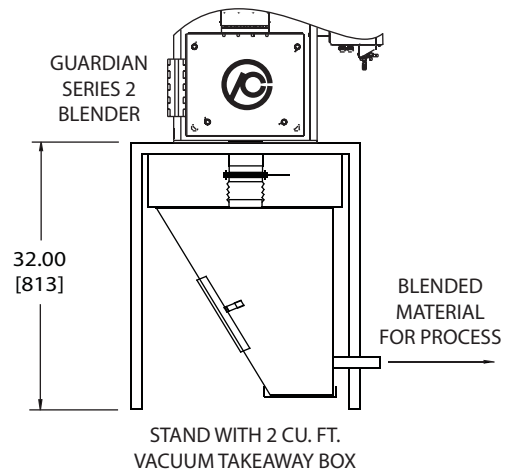
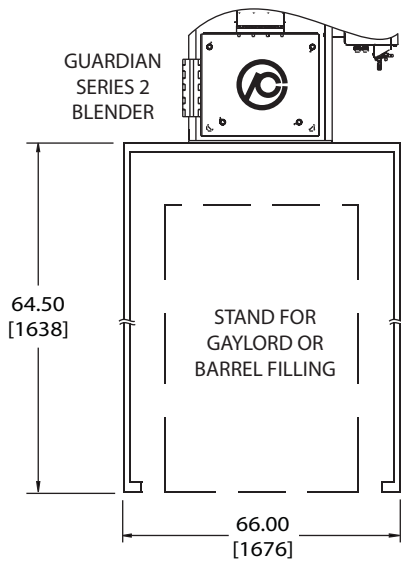

Note: Bracketed [] dimensions are in mm

Optional Features

- Optional cartridge valve restrictor plates for high accuracy at very low dosing rates
- Built-in line speed and extruder control modules available for mono-extrusion lines
- Line speed and extrusion control available for coextrusion lines with optional Gravitrol® system
- Extended cables for remote mounted touch-screen operator control panel
- Low level material hopper proximity sensors for material alarm applications
- Optional drain with butterfly valve for all material hoppers
- Optional Regrind and/or Powder Feeder elements available
- Optional painted Stainless Steel hoppers for corrosive materials applications
- Special paint colors optionally available to match your other equipment
- Built-in Self-Loading controls available
- Up to 6 elements/ingredients for the 2.5kg
- For higher throughputs, see our entire line of batch blenders, all the way up to the 25kg/55.3lb Guardian® Series 2