

HS Series

Surge Hopper



HS Series: Economical, space saving in-plant storage bins for finished or raw materials.

The HS Series Surge Hoppers from Process Control are ideal for in-plant storage of both raw materials and finished product. They are available in a variety of sizes and capacities to maximize and conserve handling time, space, and energy. Standard capacities range from 30 cu.ft. to 290 cu.ft. and are available with hopper slopes of 45° or 60° depending on the flow characteristics of the material being stored. Custom designed bins with 70° hopper slopes can also be supplied for regrinds or difficult flowing materials.

The heavy duty design of the HS

Series features welded carbon steel construction with formed angle iron legs and reinforcement bracing. The lid of the HS Series is designed for easy mounting of Process Control vacuum receivers or cyclones, and features a hinged cover for easy access. Other standard features include lifting lugs for easy placement of the bin in the plant, bolt down foot pads to securely anchor the bin to the floor, and high and low level view windows for quick visual inspection of the material level within the bin.

Process Control supplies a complete

line of material handling equipment including storage silos (bolted and welded), complete railcar unloading systems, complete in-plant distribution systems (both vacuum and pressure), tubing and hardware, and we offer experienced crews for professional installations of any size system. ■

Standard Features

- High & Low level view windows
- Lifting lugs for easy placement in plant
- Bolt-down footpads
- Heavy duty angle iron legs and reinforcement bracing
- Hopper slopes of 45° or 60°
- Hinged top cover for easy access
- Lid configured for mounting PCC vacuum receiver or cyclone
- Exterior painted standard PCC Grey
- Mild steel construction

Options

- Manual or automatically operated slide-gate discharge valve
- Vacuum take-away box with aspirated outlet stubs
- Drain tube for discharging directly into gaylord boxes, drums, or other type of container
- Leg extensions for gaylord box clearance
- High and/or low level proximity or rotary sensors
- Hopper slopes of 70° for regrinds or difficult flowing materials
- Epoxy coating on interior
- Custom paint color
- Stainless steel construction

HS Series Surge Hoppers

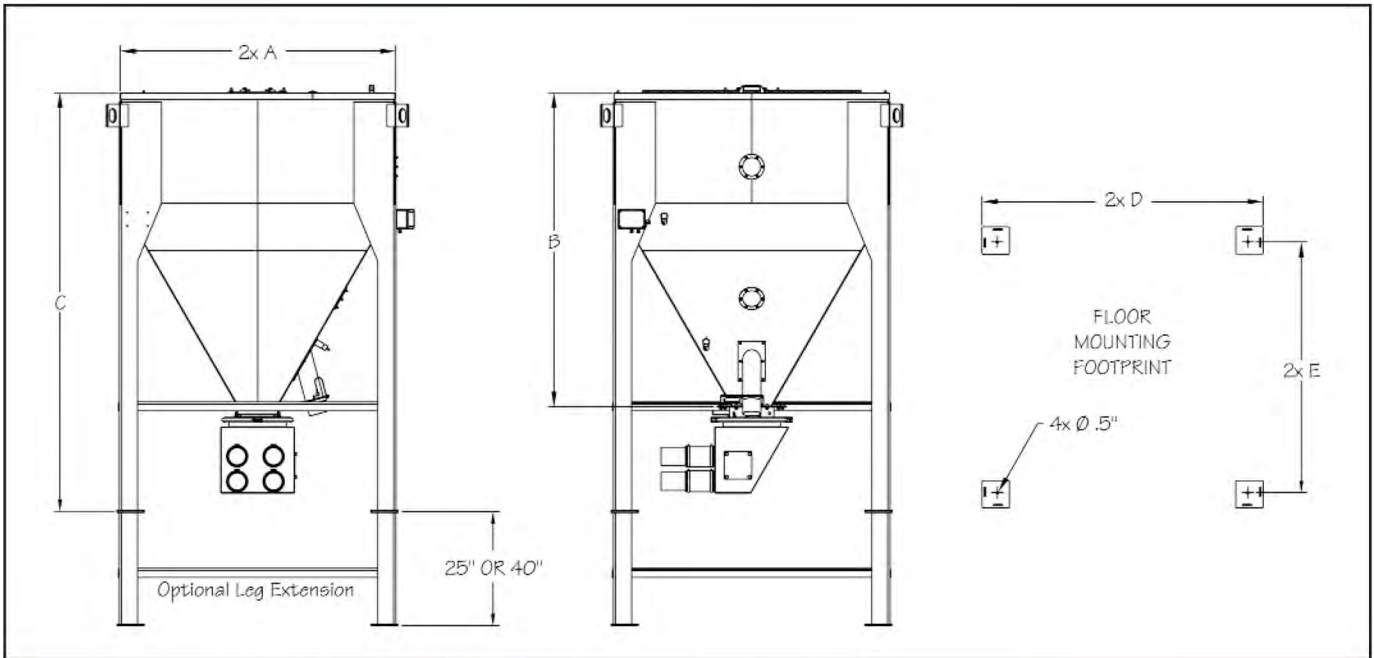

SPECIFICATIONS for 45 DEGREE HS SERIES SURGE HOPPERS

Model Number	Maximum Volume		Dimensions (Inches)					Shipping Weight Lbs
	Air cu.ft.	Usable cu.ft.	A	B	C	D	E	
HS01A	30	17	48.7	32.7	53.0	49.7	43.0	450
HS02A	60	47	48.7	54.6	77.5	49.7	55.0	575
HS03A	90	64	61.0	57.0	80.0	61.7	55.0	850
HS05A	145	125	61.1	87.2	110.1	61.7	55.0	1060
HS10A	290	251	76.0	115.3	138.2	73.7	67.0	2150

Usable volume is based on a 30 degree angle of repose

SPECIFICATIONS for 60 DEGREE HS SERIES SURGE HOPPERS

Model Number	Maximum Volume		Dimensions (Inches)					Shipping Weight Lbs
	Air cu.ft.	Usable cu.ft.	A	B	C	D	E	
HS01B	30	20	49.0	40.8	63.7	50.0	43.0	475
HS02B	60	47	49.0	63.1	86.1	50.0	43.0	600
HS03B	90	64	61.2	68.9	91.8	61.7	55.0	950
HS05B	145	125	61.2	98.9	121.9	61.7	55.0	1150
HS10B	290	251	76.0	130.1	153.0	73.7	67.0	2210

Usable volume is based on a 45 degree angle of repose



PROCESS CONTROL Corporation
 World Headquarters
 6875 Mimms Drive, Atlanta, GA 30340 USA
 Tel: (770) 449-8810 Fax: (770) 449-5445
 www.process-control.com

PROCESS CONTROL GmbH
 Industriestrasse 15, 63633 Birstein, Deutschland
 Tel: (+49) 0 60 54-91 29 0 Fax: (+49) 0 60 54-91 29 99
 E-Mail: ProcessControl@t-online.de