

LC Series

Compressed Air Loader



***The LC Series Compressed Air Vacuum Loader.
(Shown above is a LCC with custom mounting flange)***

The LC Series vacuum loader from Process Control is a space efficient, self-contained unit which uses compressed air to convey materials at rates up to 850 PPH. It can be used effectively in any application that calls for raw material delivery.

The LC Series loader is economically priced and comes equipped with all components needed to quickly load raw materials into any processing machine or storage bin. Each unit is shipped fully assembled and tested. The LC Series can be used to load pellets, regrinds, and granular type materials.

The LC Series assembly is comprised of a high efficiency cyclonic hopper mounted on a clear view tube with mounting flange, an air-flow amplifier, an exhaust air filter, and control box. Loading is controlled by a proximity sensor mounted in the view tube. All components are attached directly to the unit, making installation fast and simple. An aspirated pickup wand and 10 ft of PVC flex hose is included for pulling raw material from gaylord boxes or storage bins.

The direct-mount design of the LC Series is ideal for machine-side loading applications and eliminates the

need for bulky, machine-mounted surge hoppers. The LC Series loaders offer continuous, reliable operation with minimal required maintenance. Cleanout is quick, and fast material changes are easily accomplished without wasteful down-time for draining and cleaning common with larger surge hoppers. ■

Standard Features

- Clear view material outlet tube
- Mounting flange
- Easily accessible, top-mounted air discharge filter
- Load level proximity sensor
- Aspirated pickup wand and 10 ft of PVC flex hose
- Air operated venturi requires 80-100 psi plant compressed air. Total supply air required varies based on model and throughput.
- Power: 115V/1ph/60Hz or 230V/1ph/50Hz
- Mild steel construction

Options

- Custom mounting adapter
- Stainless steel construction
- Dual inlet for proportional loading of pellets and regrinds. Brings both material in simultaneously to eliminate layering. The percentages are set by adjusting the air pressure settings.

LC Series Compressed Air Loader

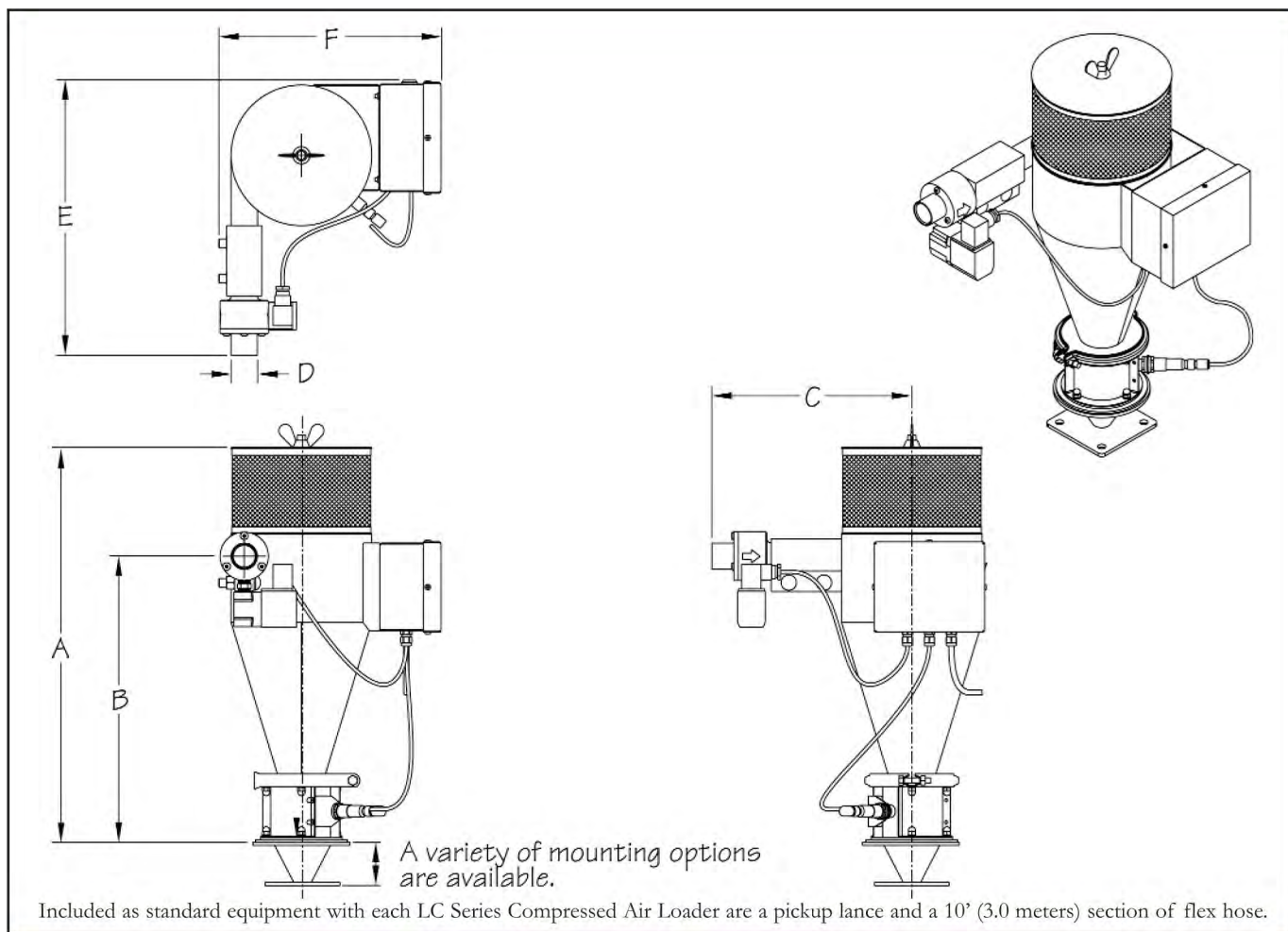

SPECIFICATIONS for LC SERIES COMPRESSED AIR LOADER

Model Number	Nominal Rate PPH (kgph)**	Max. Air Consumption @80 psig (cfm)*	Dimensions (inches)						Ship Weight lbs. (kg)
			A	B	C	D	E	F	
LCA	130 (60)	15 cfm	11.08 (281)	6.00 (152)	6.63 (168)	.75 (19)	12.59 (320)	6.28 (160)	15 (6.8)
LCB	350 (160)	15 cfm	11.08 (281)	6.00 (152)	6.63 (168)	1.00 (25)	12.59 (320)	6.28 (160)	15 (6.8)
LCC	600 (275)	25 cfm	16.20 (411)	10.43 (265)	9.38 (239)	1.25 (32)	12.64 (321)	9.87 (251)	22 (10.0)
LCD	850 (385)	33 cfm	20.94 (532)	14.81 (376)	11.38 (289)	1.50 (38)	15.64 (397)	12.63 (321)	30 (13.6)

*Note: Actual air consumption is directly proportional to conveying demand. For example: if a pellet rate of 50 pph satisfies the need of a LCB, the unit will automatically shut the air off 50% of the time and consequently use only 7.5 cfm @ 80psig.

**Note: Nominal rates are based on a conveying distance of 5 ft (1.5m) horizontal and 10 ft (3.0m) vertical

***Note: Rates can vary based on material and conveying distance.



PROCESS CONTROL Corporation
World Headquarters
 6875 Mimms Drive, Atlanta, GA 30340 USA
 Tel: (770) 449-8810 Fax: (770) 449-5445
 www.process-control.com

PROCESS CONTROL GmbH
 Industriestrasse 15, 63633 Birstein, Deutschland
 Tel: (+49) 0 60 54-91 29 0 Fax: (+49) 0 60 54-91 29 99
 E-Mail: ProcessControl@t-online.de