

# RN Series

## Vacuum Receiver for Pellets



*Easily removable pellet screen comes standard on all RN Vacuum Receivers*

The RN Series Vacuum Receiver, from Process Control, is part of a complete vacuum conveying system for in-plant distribution or machine/blender loading. When coupled with a vacuum pump and sequencing panel (both priced separately), the RN Series provides automatic loading of pellet materials.

The RN Series Vacuum Receiver is designed to be mounted at any point where resin delivery is needed. As the station calls out for a load, a sequencing panel sends a signal to the RN to open its sequencing valve and pull vacuum on this receiver. The material is pulled from the connected source until the fill cycle is complete. Then, the material is dumped from the receiver immediately (by means of a flapper valve) or held for future use (by a positive shut-off valve).

A built-in screen prevents carry-over of pellet material back to the vacuum pump. For materials which have significant fines and dust, an optional dust collector should be purchased to reduce maintenance and protect the vacuum pump. The RN Series Vacuum Receiver is low maintenance: no valves come into contact with conveyed material and no tools are needed for pellet retaining screen changes.

### Standard Features

- ◆ Air operated sequencing valve in lid requires 80-100 psi of filtered, lubricated shop air for solenoid actuators and control cylinders. The total supply air required per cycle is 0.005 cu. ft.
- ◆ 24 VDC control volta
- ◆ Flapper-type valve with magnetic switch
- ◆ Simple slide-out pellet screen with 2 latches
- ◆ Mild steel construction

### Options

- ◆ Check valve for common material line applications
- ◆ Swing-gate or knife-gate positive shut-off discharge valve
- ◆ 110VAC control voltage
- ◆ Stainless steel construction
- ◆ Director series sequencing control panel
- ◆ Central vacuum power unit
- ◆ Central dust collector
- ◆ Load level proximity switch
- ◆ High temperature design
- ◆ 12" screen available on 16" and 20" models



**PROCESS CONTROL CORPORATION**

World Headquarters  
6875 Mimms Drive, Atlanta, GA 30340 USA  
Ph 770.449.8810 Fax 770.449.5445

Process Control GmbH  
Birstein, Germany

Ph +19-6051-91 29-0 Fax +19-6051-91 29-99



# RN Series Vacuum Receiver for Pellets With Flapper Valve Discharge

2.00" [50.8]  
REQ'D FOR  
LID REMOVAL

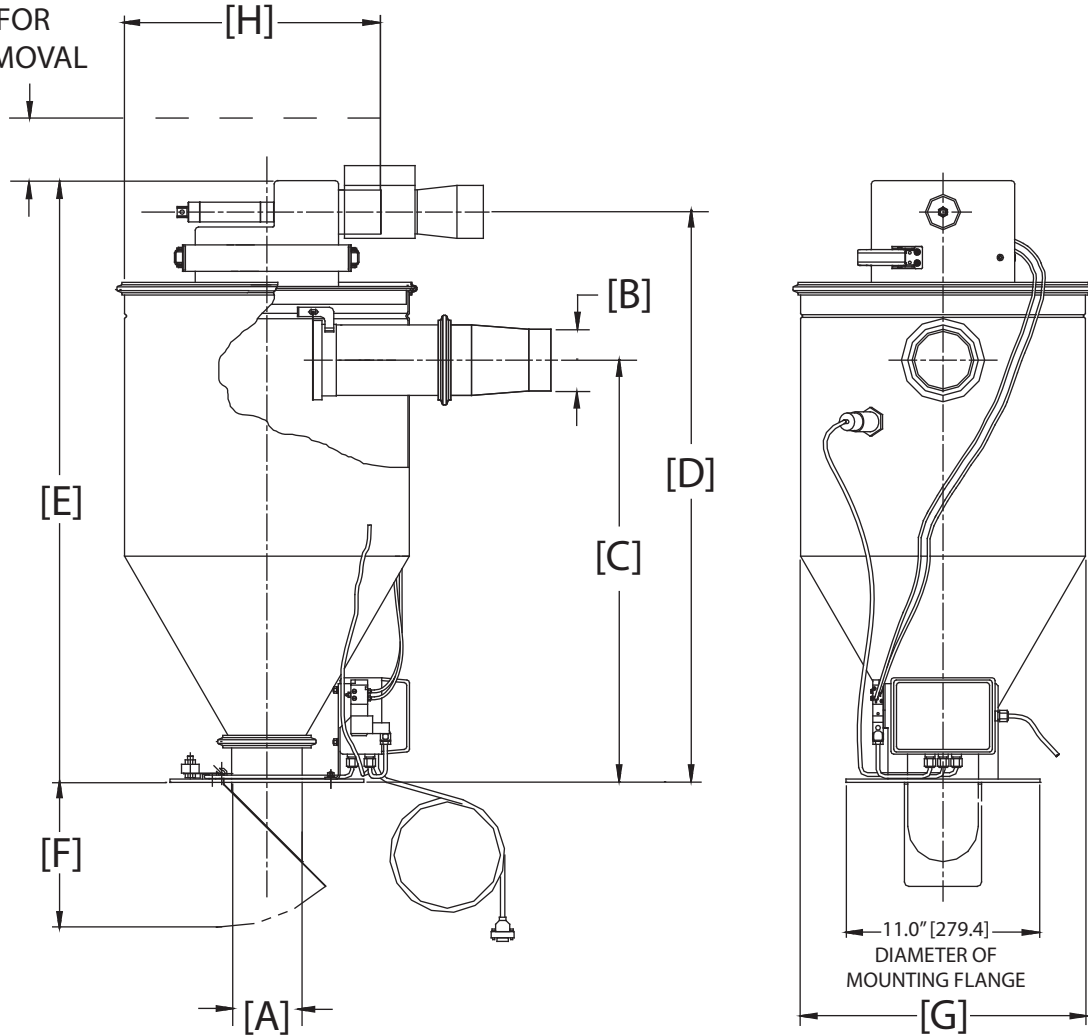

## SPECIFICATIONS for RN SERIES VACUUM RECEIVER

Model Number	Working Capacity cu. ft. [dm3]	Dimensions - Inches (mm)								Shipping Weight  Lbs (kg)
		A	B	C	D	E	F	G	H	
RNH	0.65 (18.40)	4.0 (101.6)	3.5 (88.9)	15.31 (389)	23.84 (606)	25.42 (646)	8.21 (209)	16.15 (410)	14.53 (369)	55 (24.9)
RNJ	1.44 (40.77)			23.95 (608)	32.35 (822)	34.05 (865)				
RNK	2.58 (73.05)			38.95 (989)	47.32 (1202)	49.05 (1246)				
RNL	3.14 (88.91)			30.75 (781)	41.51 (1054)	43.29 (1100)				
RNM	3.0 (84.95)									20.0 (508)



# RN Series Vacuum Receiver for Pellets With Swing-Gate Discharge Valve

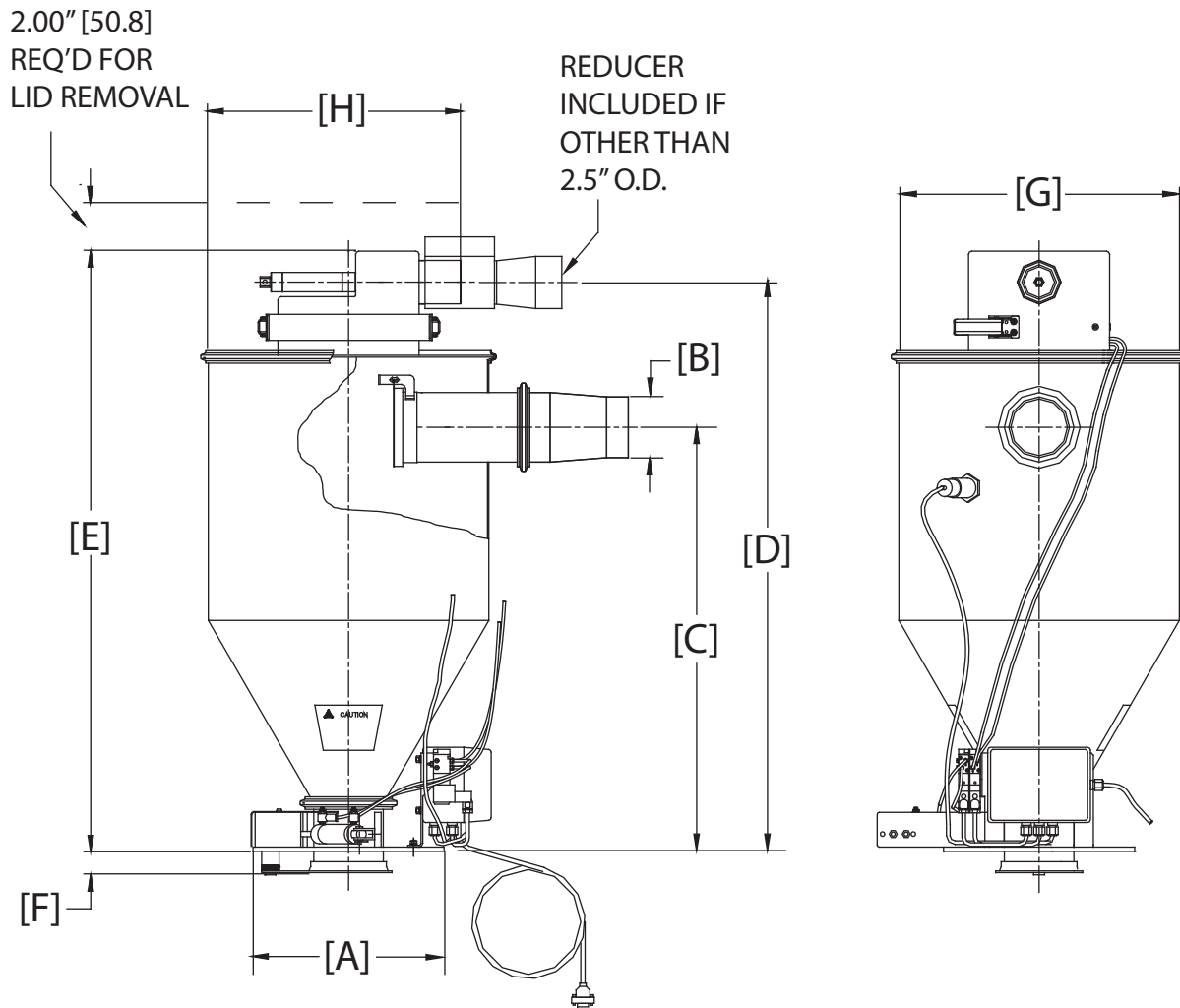

## SPECIFICATIONS for RN SERIES VACUUM RECEIVER

Model Number	Working Capacity cu. ft. (dm <sup>3</sup> )	Dimensions - Inches (mm)								Shipping Weight Lbs (kg)	
		A	B	C	D	E	F	G	H		
RNH	0.65 (18.40)	11.0 (279)	3.5 (88.9)	15.78 (401)	24.18 (614)	25.89 (658)	1.35 (34.29)	16.15 (410)	14.53 (369)	55 (24.9)	
RNJ	1.44 (40.77)			24.42 (620)	32.78 (834)	34.52 (877)					
RNK	2.58 (73.05)			39.42 (1001)	47.79 (1214)	49.52 (1258)					
RNL	3.14 (88.91)			31.03 (788)	41.96 (1066)	43.65 (1109)				20.0 (508)	18.75 (476)
RNM	3.0 (84.95)										



# RN Series Vacuum Receiver for Pellets With Knife-Gate Discharge Valve

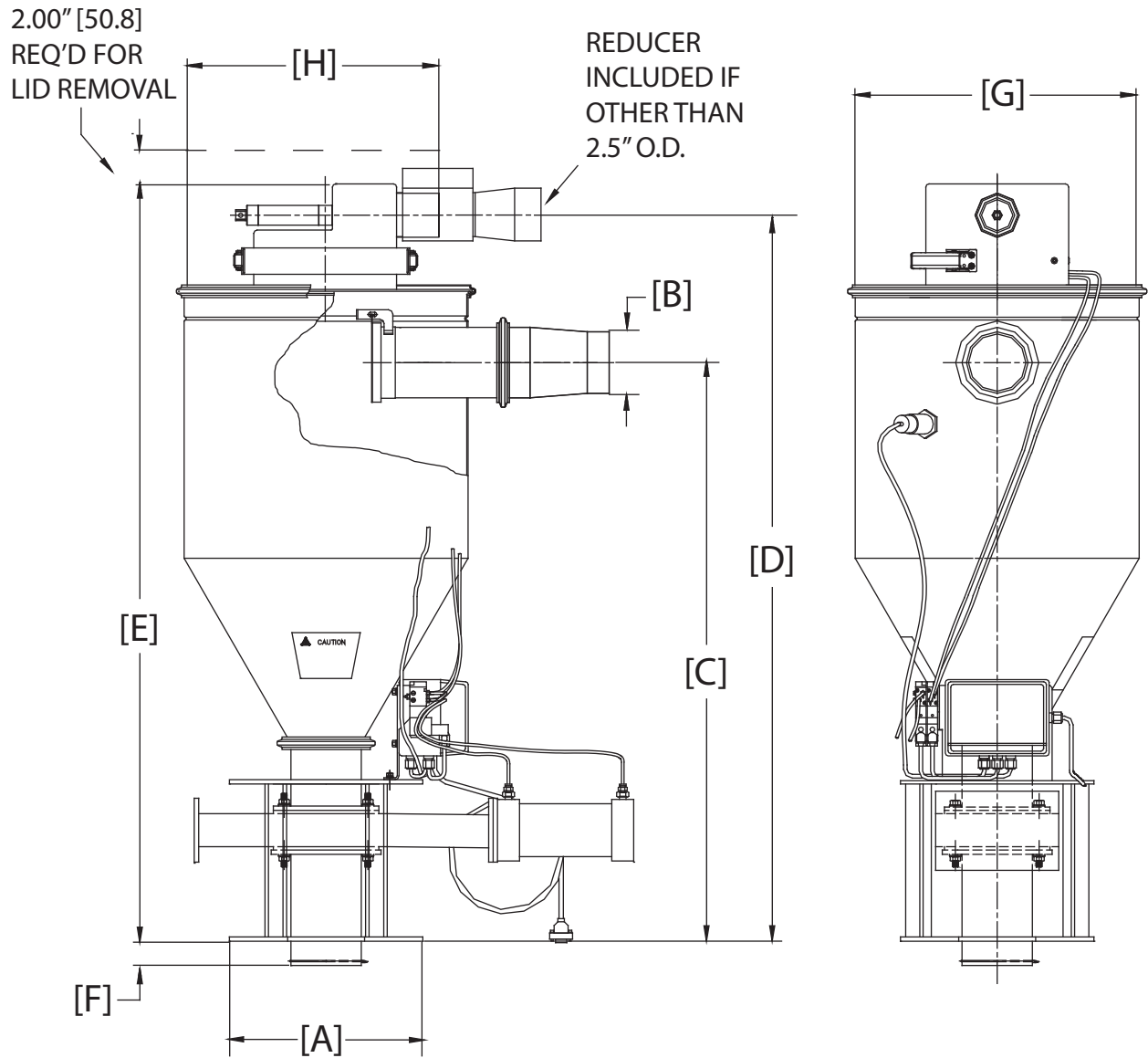

## SPECIFICATIONS for RN SERIES VACUUM RECEIVER

Model Number	Working Capacity cu. ft. [dm <sup>3</sup> ]	Dimensions - Inches (mm)								Shipping Weight Lbs (kg)
		A	B	C	D	E	F	G	H	
RNH	0.65 (18.40)	11.0 (279)	3.5 (88.9)	24.25 (616)	31.16 (792)	33.98 (863)	1.38 (34.9)	16.15 (410)	19.15 (486)	55 (24.9)
RNJ	1.44 (40.77)			32.89 (835)	41.26 (1048)	42.99 (1092)			14.48 (368)	
RNK	2.58 (73.05)			47.89 (1216)	56.26 (1429)	58.10 (1476)			65 (29.4)	
RNL	3.14 (88.91)			36.90 (937)	47.66 (1211)	49.34 (1253)				
RNM	3.0 (84.95)									20.00 (508)





**PROCESS CONTROL CORPORATION**

**HEADQUARTERS**

6875 Mimms Drive  
Atlanta, GA 30340, USA

P: 770.449.8810

F: 770.449.5445

sales@process-control.com

www.process-control.com

**PCC GmbH**

Industriestrasse 15

63633 Birstein, Deutschland

P: (+49) 0 60 54-91 29 0

F: (+49) 0 60 54-91 29 99

info@processcontrol-gmbh.de

www.processcontrol-gmbh.de

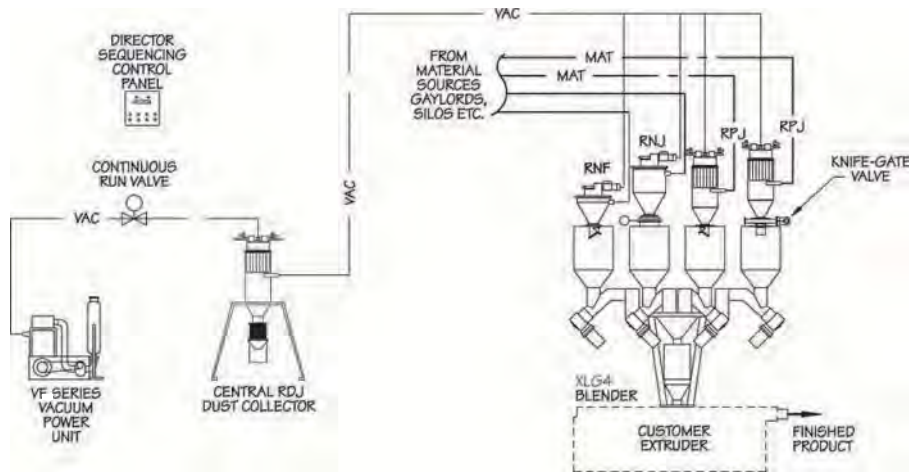

\*Schematic above depicts typical Gravimetric Blender Loading Systems

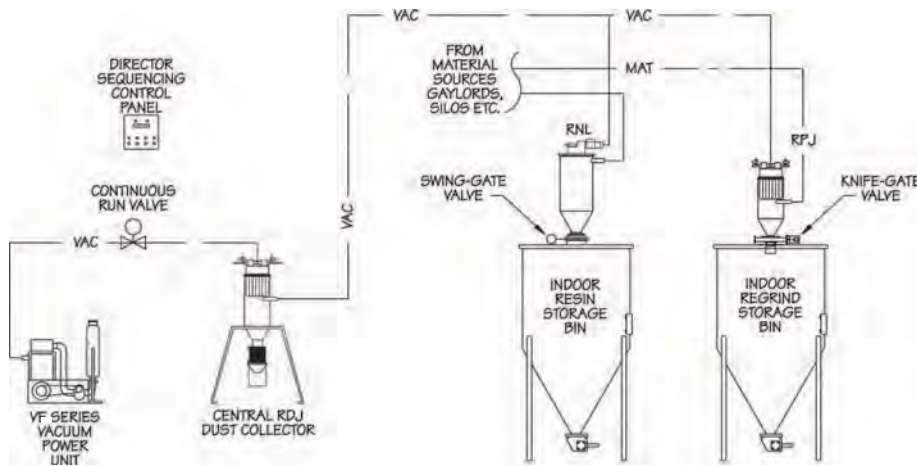

\*Schematic above depicts typical in-plant material Storage Bin Loading System

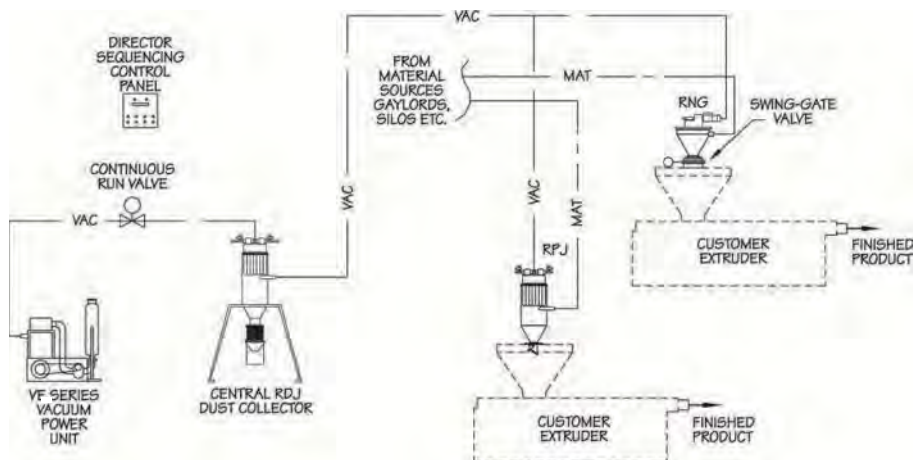

\*Schematic above depicts typical Extruder Loading System