

VF Series

Vacuum Power Unit



VF Series with Sound Enclosure

Process Control's material handling equipment is specifically designed for bulk conveying of plastic materials. Years of experience with plastic processors enable Process Control engineers to properly size conveying equipment for reliable, cost-effective loading of gravimetric or bulk systems. A complete line of equipment is available including pumps, receivers, controllers, bulk storage silos, day bins and hardware necessary for railcar unloading and integrated plant distribution systems. Compact, simple systems are available for lower throughput applications.

The VF Series is our most popular line of vacuum power units, offering dependable and economical performance for a wide variety of conveying rates, distances and materials. Typical applications include in-plant distribution systems and machine/blender loading. Each system is carefully sized using PCC's computer calculations to meet your conveying specifications.

Standard Features

- ◆ 3 to 30 horsepower available
- ◆ Positive displacement blower
- ◆ Enclosed, V-belt drive
- ◆ Single element paper filter assembly
- ◆ T-frame TEFC motor (indoor and outdoor)
- ◆ Discharge silencer
- ◆ Vacuum relief valve and gauge
- ◆ Motor starter panel

Options

- ◆ Variable Speed Drive controlled
- ◆ Special voltages
- ◆ Continuous run valve to reduce pump cycling
- ◆ Sound-deadening enclosures
- ◆ Outdoor construction



PROCESS CONTROL CORPORATION

World Headquarters
6875 Mimms Drive, Atlanta, GA 30340 USA
Ph 770.449.8810 Fax 770.449.5445

Process Control GmbH
Birstein, Germany
Ph +19-6051-91 29-0 Fax +19-6051-91 29-99

Standard 3-10HP VF Series Vacuum Power Unit

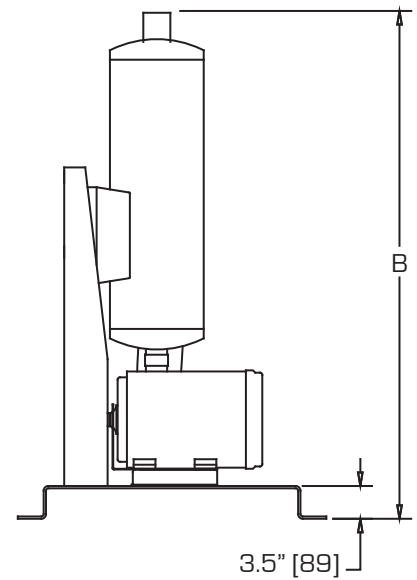
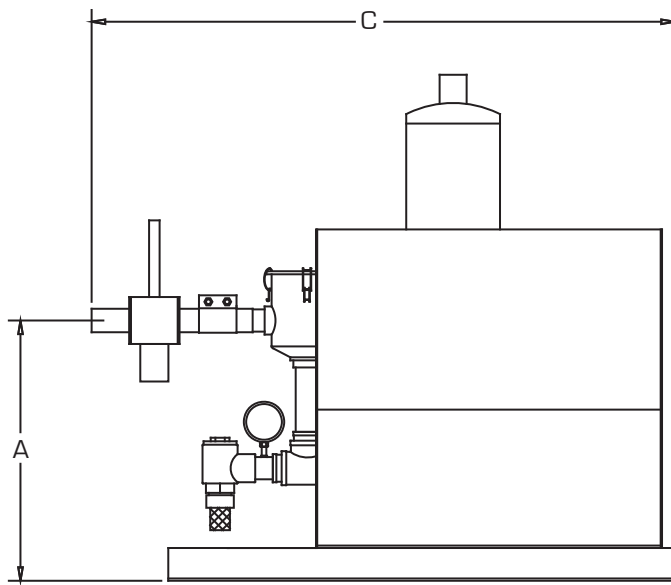
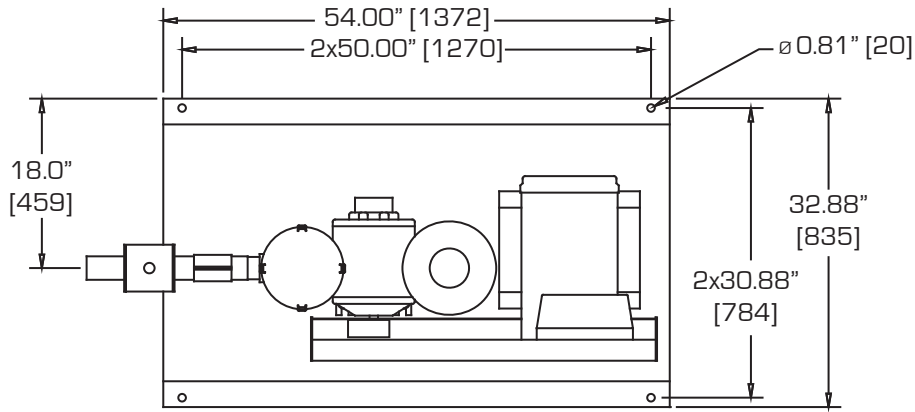

Specifications for Standard 3-10HP VF Series Vacuum Power Unit

Model Number	Power HP (kW)	Standard Tube Size in (mm)	A in (mm)	B in (mm)	C in (mm)	Shipping Weight lbs (kg)
VF03	3 (2.2)	2.0 (51)	25.7 (651)	43.7 (1110)	59.3 (1505)	300 (136)
VF05	5 (3.7)		24.4 (619)	51.6 (1311)	60.3 (1532)	350 (159)
VF07	7.5 (5.6)	2.5 (64)	24.0 (608)	53.1 (1350)	61.8 (1570)	375 (170)
VF10	10 (7.5)	3.0 (77)	23.1 (587)	65.2 (1574)	62.0 (1574)	425 (193)

Dimension C includes continuous run valve (models VF *Y)

Sound Enclosed 3-10HP VF Series Vacuum Power Unit

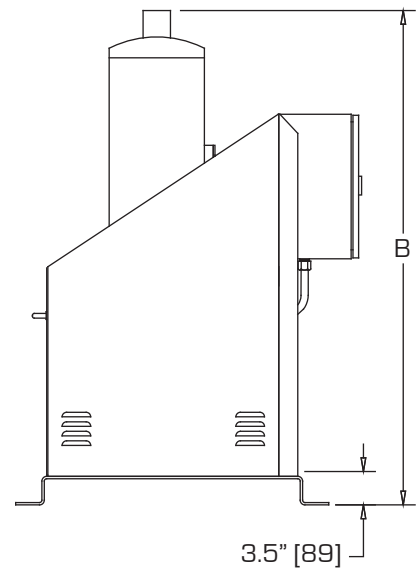
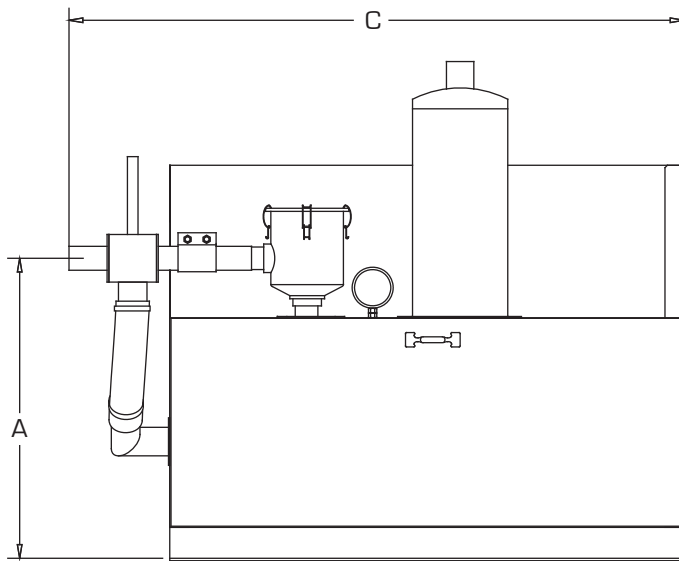
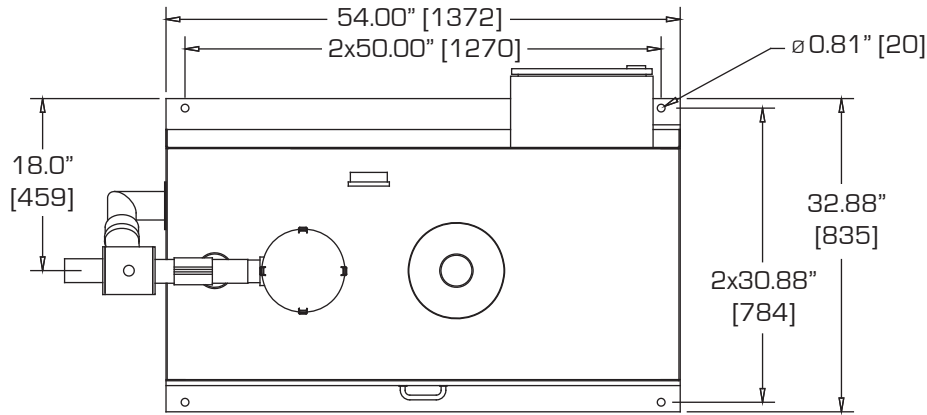

Specifications for Sound Enclosed 3-10HP VF Series Vacuum Power Unit

Model Number	Power HP (kW)	Standard Tube Size in (mm)	A in (mm)	B in (mm)	C in (mm)	Shipping Weight lbs (kg)
VF03Z	3 (2.2)	2.0 [51]	31.9 [811]	43.7 [1110]	59.3 [1505]	350 (159)
VF05Z	5 (3.7)		34.0 [864]	51.6 [1311]	60.3 [1532]	400 (182)
VF07Z	7.5 (5.6)	2.5 [64]	30.0 [762]	53.1 [1350]	61.8 [1570]	425 (193)
VF10Z	10 (7.5)	3.0 [77]	30.2 [767]	65.2 [1574]	62.0 [1574]	475 (216)

15-30HP VF Series Vacuum Power Unit

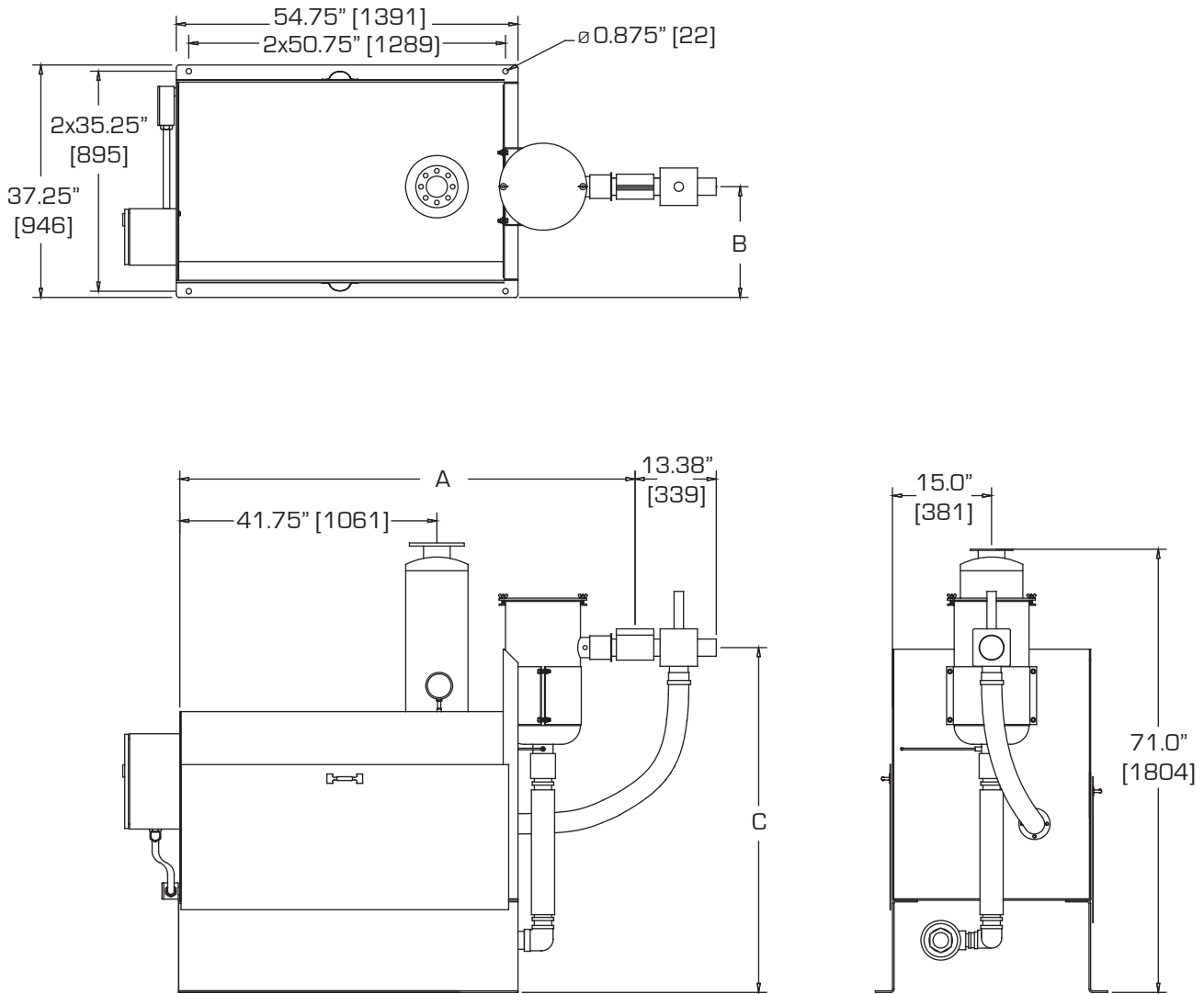

Specifications for 15-30HP VF Series Vacuum Power Unit

Model Number	Power HP [kW]	Standard Tube Size in [mm]	A in [mm]	B in [mm]	C in [mm]	Shipping Weight lbs [kg]
VF15	15 [11.2]	3.5 [89]	73.0 [1853]	17.75 [451]	55.25 [1403]	600 [273]
VF20	20 [15.0]	4.0 [102]				625 [285]
VF25	25 [18.7]	4.5 [114]				650 [295]
VF30	30 [22.4]	5.0 [127]	Consult Factory			